

IMPORTANT SAFETY AND INSTALLATION INSTRUCTIONS

WARNING: Risk of fire and electrical shock. This product is to be installed by a qualified electrician only.

CAUTION: When using electrical equipment, basic safety precautions should always be followed including the following: Read all instructions carefully before installation and save

for future use. Make sure installation and all connections are in accordance with National Electrical Code and any local regulations. To avoid possible electrical shock, be sure that power supply is turned off before installing or servicing this fixture. Servicing should be performed by qualified service personnel.

These instructions do not claim to cover all details or variations. When additional information is desired, please contact your SPI representative.

MARKER LIGHT WET LOCATION

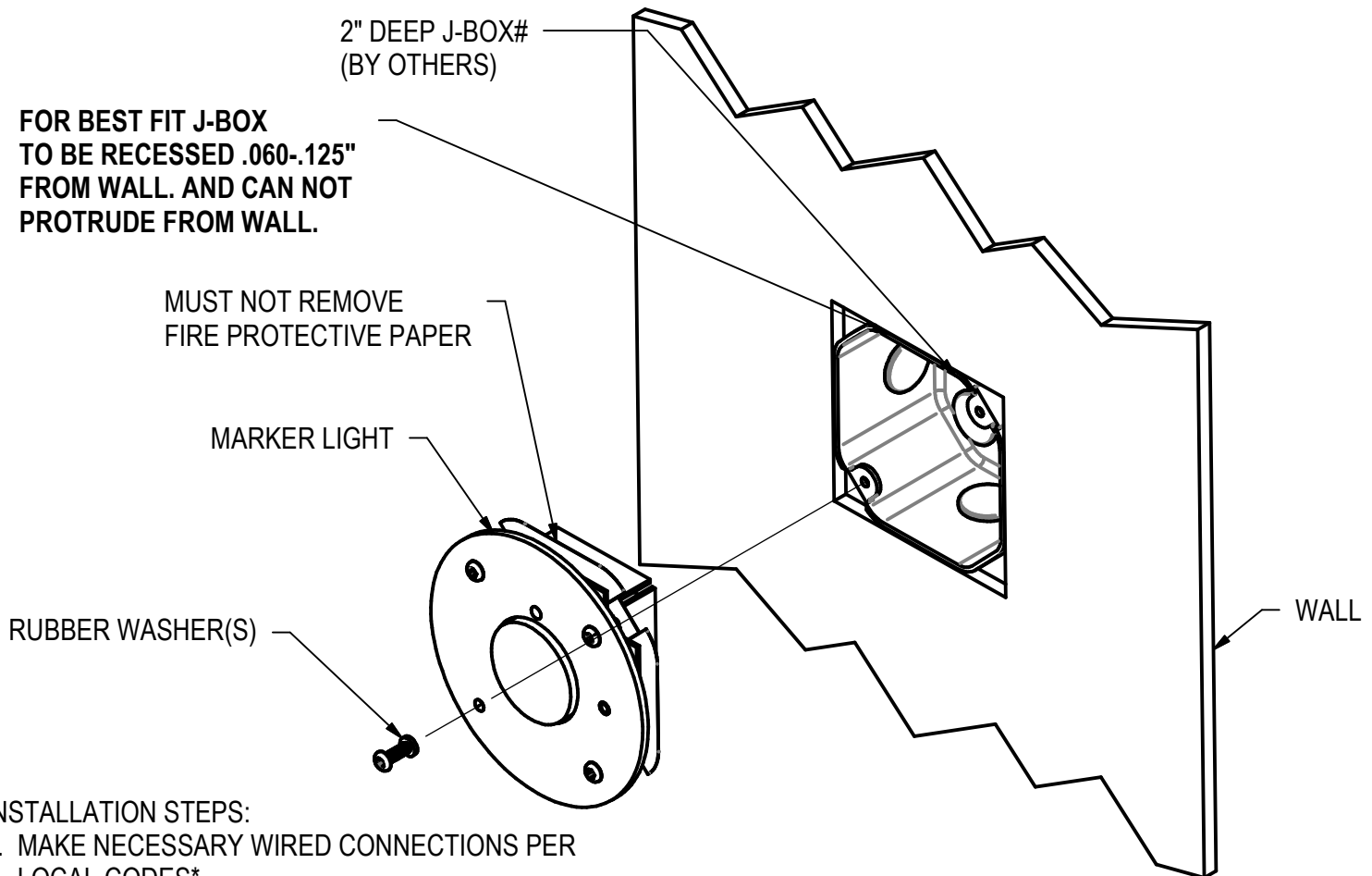

INSTALLATION STEPS:

1. MAKE NECESSARY WIRED CONNECTIONS PER LOCAL CODES*.
2. PLACE MARKER LIGHT INTO J-BOX AND FASTEN WITH TORX SCREWS AND RUBBER WASHERS.
3. APPLY RTV OR EQUIVALENT SEAL BETWEEN WALL AND MOUNTING PLATE ON ALL SIDES.

***NOTE THAT INCOMING POWER MUST COME IN THROUGH SIDE OF J-BOX AND NOT THROUGH THE BACK.**

#JUNCTION BOX RECOMMENDED IS FROM T&B; P/N 541711 OR EQUIVALENT SHOULD BE USED WITH THIS PRODUCT.

05/20/2014
IS80199X