

# IMPORTANT SAFETY AND INSTALLATION INSTRUCTIONS

**WARNING:** Risk of fire and electrical shock. This product is to be installed by a qualified electrician only.

**CAUTION:** When using electrical equipment, basic safety precautions should always be followed including the following: Read all instructions carefully before installation and save

for future use. Make sure installation and all connections are in accordance with National Electrical Code and any local regulations. To avoid possible electrical shock, be sure that the power supply is turned off before installing or servicing this fixture. Servicing should be performed by qualified service personnel.

These instructions do not claim to cover all details or variations. When additional information is desired, please contact your SPI representative.

---

## ECHO BLADE MICRO MAX EXT. - REMOTE DRIVER - SCN/MUL

---

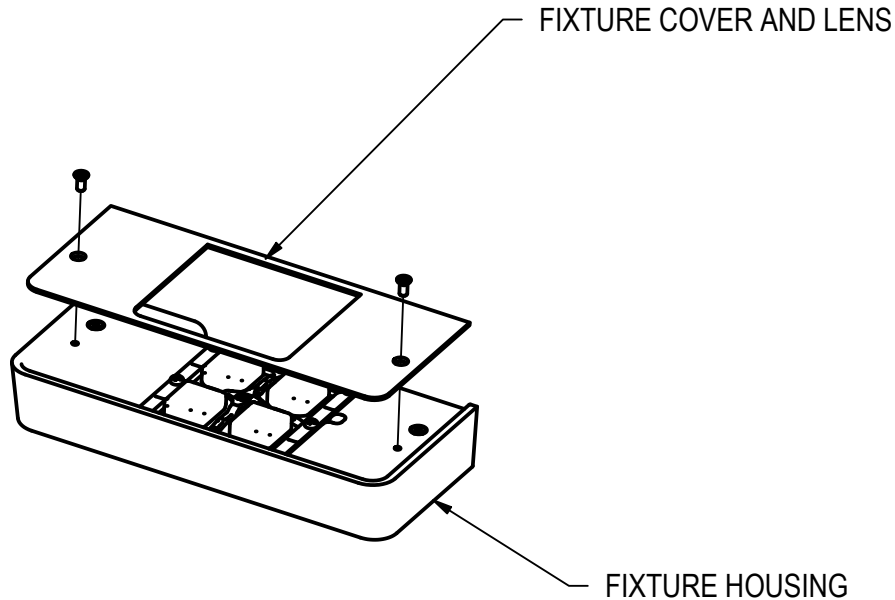

### INSTALLATION:

1. REMOVE FIXTURE COVER AND LENS.
2. LOCATE MOUNTING SCREWS (BY OTHERS) USING PROVIDED DRAWING, OR BY USING FIXTURE MOUNTING BRACKET AS TEMPLATE.

(CONTINUED ON PAGE 2)

### FIXTURE MOUNTING HOLE LOCATIONS

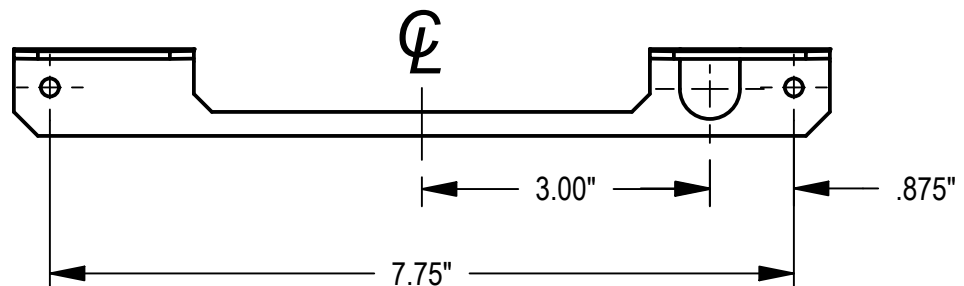

8/5/25  
IS121228X

# IMPORTANT SAFETY AND INSTALLATION INSTRUCTIONS

**WARNING:** Risk of fire and electrical shock. This product is to be installed by a qualified electrician only.

**CAUTION:** When using electrical equipment, basic safety precautions should always be followed including the following: Read all instructions carefully before installation and save

for future use. Make sure installation and all connections are in accordance with National Electrical Code and any local regulations. To avoid possible electrical shock, be sure that the power supply is turned off before installing or servicing this fixture. Servicing should be performed by qualified service personnel.

These instructions do not claim to cover all details or variations. When additional information is desired, please contact your SPI representative.

---

## ECHO BLADE MICRO MAX EXT. - REMOTE DRIVER - SCN/MUL

---

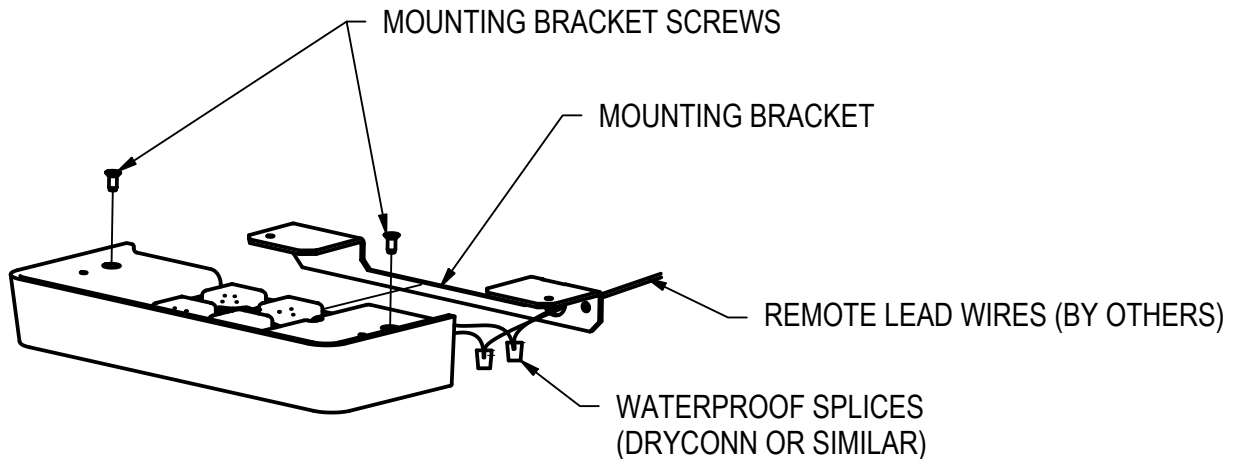

NOTE: PRODUCT SUPPLIED WITH CLASS 2 REMOTE POWER SUPPLY.

(CONTINUED FROM PAGE 1)

3. ATTACH MOUNTING BRACKET TO SURFACE WITH #8 OR LARGER SCREWS (BY OTHERS).

4. MAKE ALL WIRE CONNECTIONS IN ACCORDANCE WITH STATE AND LOCAL CODE.

- CONNECT THE RED (POS+) AND BLUE (NEG-) WIRES TO THE CORRESPONDING RED (POS+) OR BLUE (NEG-) WIRES OF THE POWER SUPPLY USING 18 GAUGE OR LARGER REMOTE LEAD WIRES (BY OTHERS). THE POLARITY OF THE FIXTURE WIRES (POS+) OR (NEG-) MUST MATCH THE POLARITY OF THE POWER SUPPLY WIRES. WIRES LABELED WITH THE SAME SUPPLY NUMBER MUST BE ATTACHED TO THE SAME POWER SUPPLY.

- IN THE SUPPLIED REMOTE POWER SUPPLY ENCLOSURE CONNECT THE HIGH VOLTAGE SUPPLY LEADS TO THE BRANCH CIRCUIT WIRE OR CAP-OFF DIMMING LEADS IF APPLICABLE.

5. SLIDE FIXTURE HOUSING OVER MOUNTING BRACKET AND FASTEN WITH PROVIDED SCREWS.

6. REINSTALL LENS (SHINY SIDE OF LENS FACES OUT) AND TOP COVER.

8/5/25  
IS121228X